

UTILITIES AND SERVICE REQUIREMENTS

ELECTRICAL	208/360/480 3 PH, 60 HZ
	8 H.P. (5.97 KW) CONNECTED LOAD
ELECTRIC HEAT (OPTIONAL)	208/360/480 3 PH, 60 HZ, 24 KW
STEAM	1 1/2" (3.81 CM) FPT 30-80 PSI (206.84-551.58 KPA)
	350 LBS/HR (158.76 KG/HR) PEAK FLOW RATE
	250 LBS/HR (113.40 KG/HR) AVERAGE FLOW RATE
CONDENSATE	1" (2.54 CM) FPT
HOT WATER	1" (2.54 CM) FPT 35 PSI (241.32 KPA) 180 DEG. F. (82.22 DEG C)
	90 GALLONS (340.69 LITERS) MAX. / LOAD CONSUMPTION
COLD WATER (OPTIONAL)	3/4" (1.91 CM) FPT 35 PSI (241.32 KPA) 50 DEG. F. (10 DEG C)
	15 GPM (56.78 LITERS/MIN) AVERAGE FLOW
DRAIN	1 1/2" (3.81 CM) FPT 190 DEG. F. (87.78 DEG C) MAX. TEMPERATURE
	60 GPM (227.12 LITERS/MIN) FLOW RATE
EXHAUST	6" (15.24 CM) DIA. 180 DEG. F. (82.22 DEG C) SATURATED
	200 CFM (5.66 CUBIC METERS/MIN) FLOW RATE
COMPRESSED AIR	1/2" (1.27 CM) FPT 80 PSI (551.58 KPA)
	4 SCFM (0.11 CUBIC METERS/MIN) FLOW RATE

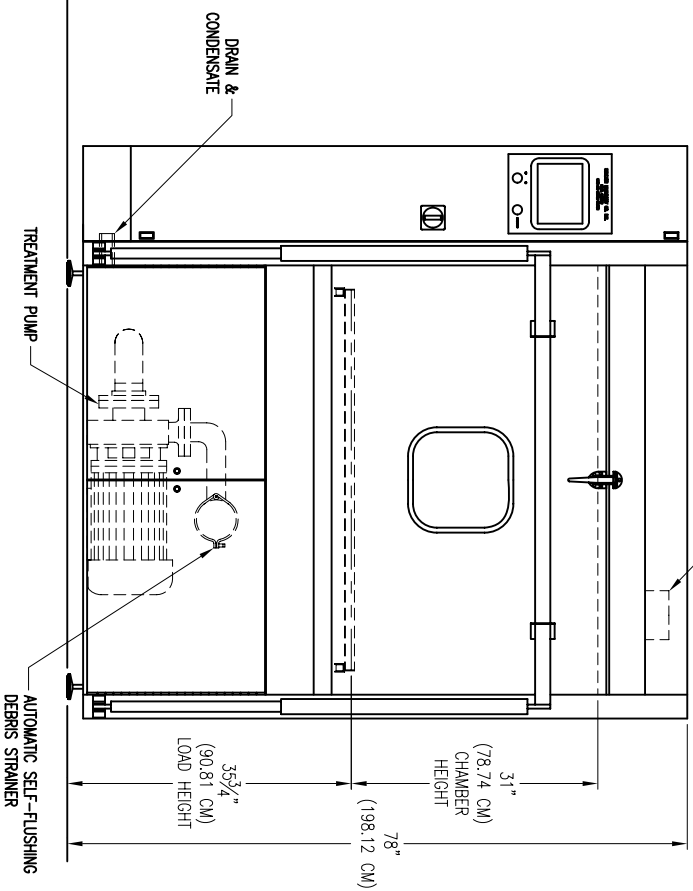
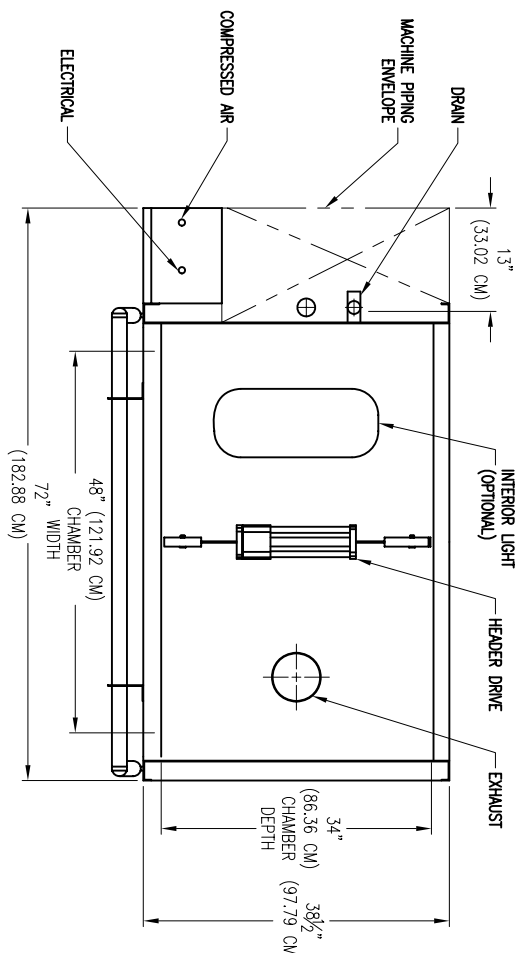
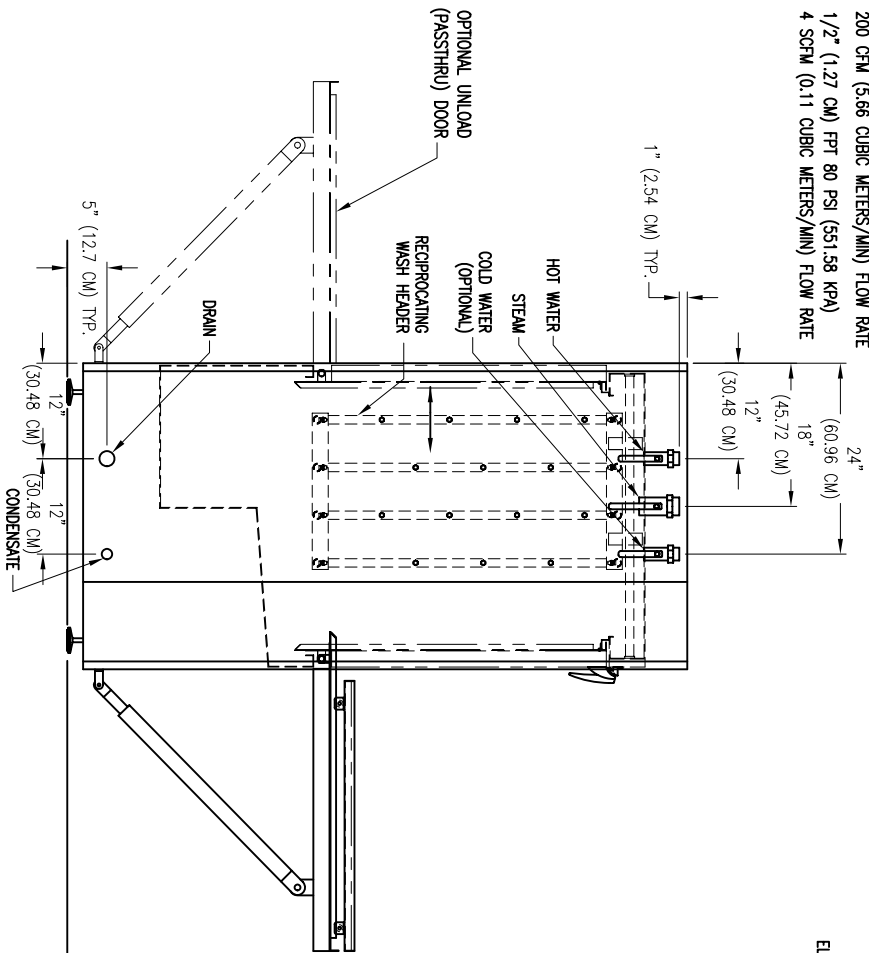

NOTICE: All drawings, descriptions, prints, specifications, etc. bearing this notice, together with the information, and ideas contained therein, are the sole and exclusive property of Schlyer Machine. Any disclosure or use thereof not authorized in writing by Schlyer Machine is unlawful and will be prosecuted to the full extent of the law.

DWG. BY: GREG B DATE: 2/28/05
 APP. BY: DATE:
 SCALE: JOB NO:
 SHEET: 1 OF 1 NEXT ASSEMBLY:

DRAWING TITLE: MODEL CBW1026LS LH CAGE AND BOTTLE WASHER
 SCHLYER MACHINERY CO. PART NO:
 200 LAKE ST. WILSON, NY 14172 CBW1026LS L